



APT14, APT14HC and APT14SHC Automatic Pump Traps

Description

The Spirax Sarco APT14, APT14HC and APT14SHC automatic pump traps are flanged or screwed displacement receivers pressure rated to PN16. The units are capable of automatically trapping or pumping, depending on pipeline conditions. The unit is operated by steam and is used to remove condensate from process plant under all operating conditions including vacuum. For optional extras see 'How to order' on page 5.

Design compliance - The shell of the product has been designed in accordance with A.D. Merkblatter/ASME VIII.

Certification - These products are available with certification to EN 10204 3.1. **Note:** All certification/inspection requirements must be stated at the time of order placement.

Sizes and pipe connections

Model and body material	Inlet and outlet sizes and pipe connections	Connections			
		Motive / exhaust	Sight glass	Drain	
APT14 SG iron	Flanged DN40 inlet x DN25 outlet	EN 1092 PN16	BSP or NPT DN15 (1/2")	BSP DN15 (1/2")	BSP DN10 (3/8")
		ASME B 16.5 150	NPT DN15 (1/2")	NPT DN15 (1/2")	NPT DN10 (3/8")
		JIS 10 (JIS B 2210)	BSP DN15 (1/2")	BSP DN15 (1/2")	BSP DN10 (3/8")
		KS 10 (KS B 1511)	BSP DN15 (1/2")	BSP DN15 (1/2")	BSP DN10 (3/8")
	Screwed 1 1/2" inlet x 1" outlet	BSP (BS 21 parallel)	BSP DN15 (1/2")	BSP DN15 (1/2")	BSP DN10 (3/8")
		NPT	NPT DN15 (1/2")	NPT DN15 (1/2")	NPT DN10 (3/8")
APT14HC SG iron	Flanged DN50 inlet x DN40 outlet	EN 1092 PN16	BSP DN15 (1/2")	BSP DN15 (1/2")	BSP DN10 (3/8")
		ASME B 16.5 150	NPT DN15 (1/2")	NPT DN15 (1/2")	NPT DN10 (3/8")
JIS 10 (JIS B 2210)		BSP DN15 (1/2")	BSP DN15 (1/2")	BSP DN10 (3/8")	
KS 10 (KS B 1511)		BSP DN15 (1/2")	BSP DN15 (1/2")	BSP DN10 (3/8")	
APT14SHC Carbon steel					

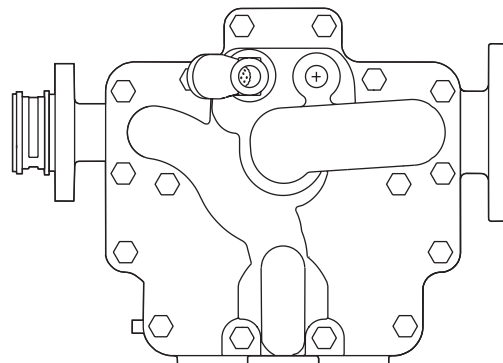
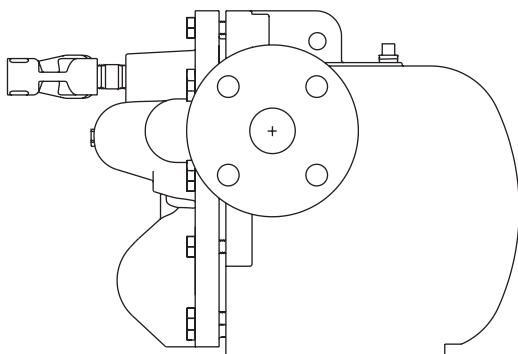

Pressure / temperature limits

APT14 and APT14HC (SG iron)

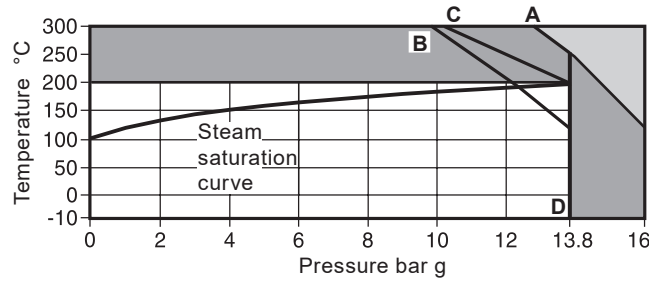

APT14SHC (carbon steel)

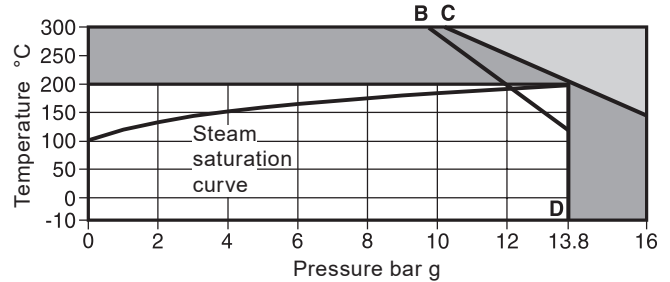
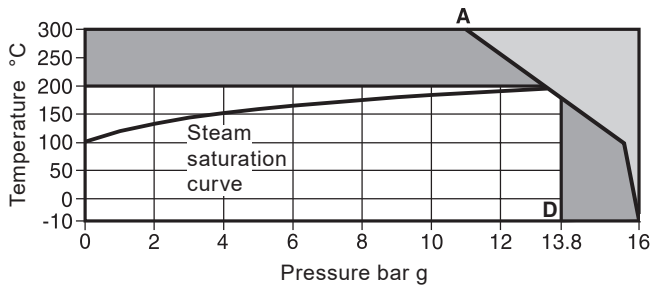

 The product **must not** be used in this region.

 The product should not be used in this region or beyond its operating range as damage to the internals may occur.

A - D Flanged PN16.

B - D Flanged JIS/KS 10.

C - D Flanged ASME 150.

Body design conditions	PN16	
Maximum motive inlet pressure	13.8 bar g	
PMA Maximum allowable pressure	16 bar g @ 120 °C	
TMA Maximum allowable temperature	300 °C @ 12.8 bar g	
Minimum allowable temperature Note: For lower temperatures consult Spirax Sarco.	-10 °C	
PMO Maximum operating pressure for saturated steam service	13.8 bar g @ 198 °C	
Maximum backpressure for standard pumps (for higher backpressures contact Spirax Sarco)	5 bar g	
TMO Maximum operating temperature for saturated steam service	198 °C @ 13.8 bar g	
Minimum operating temperature Note: For lower temperatures consult Spirax Sarco	-10 °C	
Temperature limits (Ambient )	-10 °C to 200 °C	
Designed for a maximum cold hydraulic test pressure of:	24 bar g	
Filling/ Installation	Recommended filling head above the pump (from the base of the receiver/process)	0.3 m
	Maximum recommended installation (from the base of the pump) for higher installation heads refer to Spirax Sarco	1 m
	Minimum installation head required (from the base of the pump)	0.2 m

Nominal capacities

For full capacity details for a specific application consult Spirax Sarco. To accurately size the pump trap, the following data is required.

1. Installation head available, from the base of the pump trap to the centre line of the heat exchanger / process condensate outlet (m). If the outlet is mounted vertically, then this should be from the base of the pump to the face of the outlet.
2. Motive steam pressure available to power the pump trap (bar g).
3. Total backpressure in the condensate return system (bar g). See note below.
4. Heat exchanger full-load operating pressure (bar g).
5. Heat exchanger maximum steam load (kg/h).
6. Minimum temperature of secondary fluid (°C).
7. Maximum controlled temperature of secondary fluid (°C).

Model	APT14	APT14HC and APT14SHC
Pump discharge/cycle	5 litres	8 litres
1 metre installation head At: 5 bar g motive pressure 1 bar g total backpressure	Maximum trapping capacity 4 000 kg/h Maximum pumping capacity 1 100 kg/h	Maximum trapping capacity 9 000 kg/h Maximum pumping capacity 2 800 kg/h

Note:

The capacities detailed within the above Table are only given as a guide. They are based on the installation parameters shown in the left hand column.

Achieved capacities will differ if any of the installation parameters change. For specific capacities and application details, contact Spirax Sarco.

The total lift or backpressure BP (static head plus pressure head in the return system) must be below the motive fluid inlet pressure to allow pump capacity to be achieved.

$$BP \text{ (backpressure)} = (H \times 0.098 \text{ 1}) + (P) + (Pf)$$

Height (H) in metres x 0.098 1 plus pressure (P) bar g in the return line, plus downstream piping friction pressure drop (Pf) in bar. (Pf can be ignored if the downstream pipework is less than 100 metres to a non-flooded condensate return and has been sized to take into account the effect of flash steam at the heat exchanger's full-load operating conditions.)

Dimensions/weight (approximate) in mm and kg

Withdrawal distance

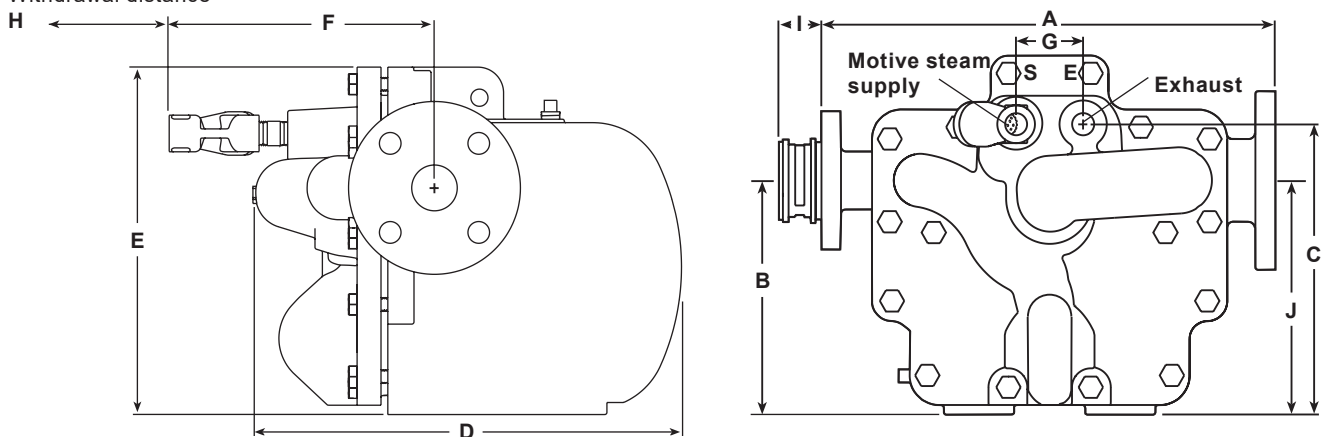

Model	Connection	A				B	C	D	E	F	G	H	I				J	Weight
		BSP/NPT	PN16	JIS/KS10	ASME								Screwed BSP/NPT	PN16	Flanged JIS/KS10	ASME		
APT14	Screwed	350	389	385	386.5	198	246	385	304	258	57	250	-	-	-	-	198	45
APT14HC	Flanged	-	512	506	524	198	270	400	335	261	57	275	-	31.5	31.5	45	198	65
APT14SHC	Flanged	-	552	546	544	206	278	407	351	261	57	275	-	31.5	31.5	45	206	105

Materials

No.	Part	Material	
1	Cover	APT14	SG iron EN JS 1025 or ASTM A395
		APT14HC	SG iron EN JS 1025 or ASTM A395
		APT14SHC	Carbon steel EN 1.0619+N or ASTM A216 WCB
2	Cover gasket	APT14	Graphite laminated with stainless steel insert
		APT14HC	Graphite laminated with stainless steel insert
		APT14SHC	Novapit SSTC expanded graphite laminated with stainless steel insert
3	Body	APT14	SG iron EN JS 1025 or ASTM A395
		APT14HC	SG iron EN JS 1025 or ASTM A395
		APT14SHC	Carbon steel EN 1.0619+N or ASTM A216 WCB
4	Cover bolts	Stainless steel	ISO 3506 Gr. A2 70
	Location pins	APT14SHC only	Stainless steel 304
5	Pump lever	Stainless steel	BS 1449 304 S15
6	Float	Stainless steel	BS 1449 304 S15
7	Trap lever	Stainless steel	BS 1449 304 S15
11	Seat (inlet check valve)	Stainless steel	AISI 420
12	Flap (inlet check valve)	Stainless steel	BS 3146 ANC 4B
13	Pump mechanism bracket	Stainless steel	BS 3146 ANC 4B
14	Spring (pump)	Stainless steel	BS 2056 302 S26 Gr. 2
16	Exhaust seat	Stainless steel	BS 970 431 S29 or ASTM A276 431
17	Inlet valve and seat assembly	Stainless steel	
18	Exhaust valve	Stainless steel	BS 3146 ANC 2
19	Valve seat gasket	Stainless steel	BS 1449 409 S19
20	Pump mechanism bolt	Stainless steel	ISO 3506 Gr. A2 70
24	Actuator arm	Stainless steel	BS 3146 ANC 2
25	Name-plate	Stainless steel	BS 1449 304 S16
26	Drain plug	Steel	DIN 17440 1.4571
27	Inlet valve spring	Stainless steel	
28	Motive strainer	APT14	SG iron
		APT14HC	SG iron
		APT14SHC	Carbon steel
29	DCV10 (APT14HC and APT14SHC)	Stainless steel (not shown)	

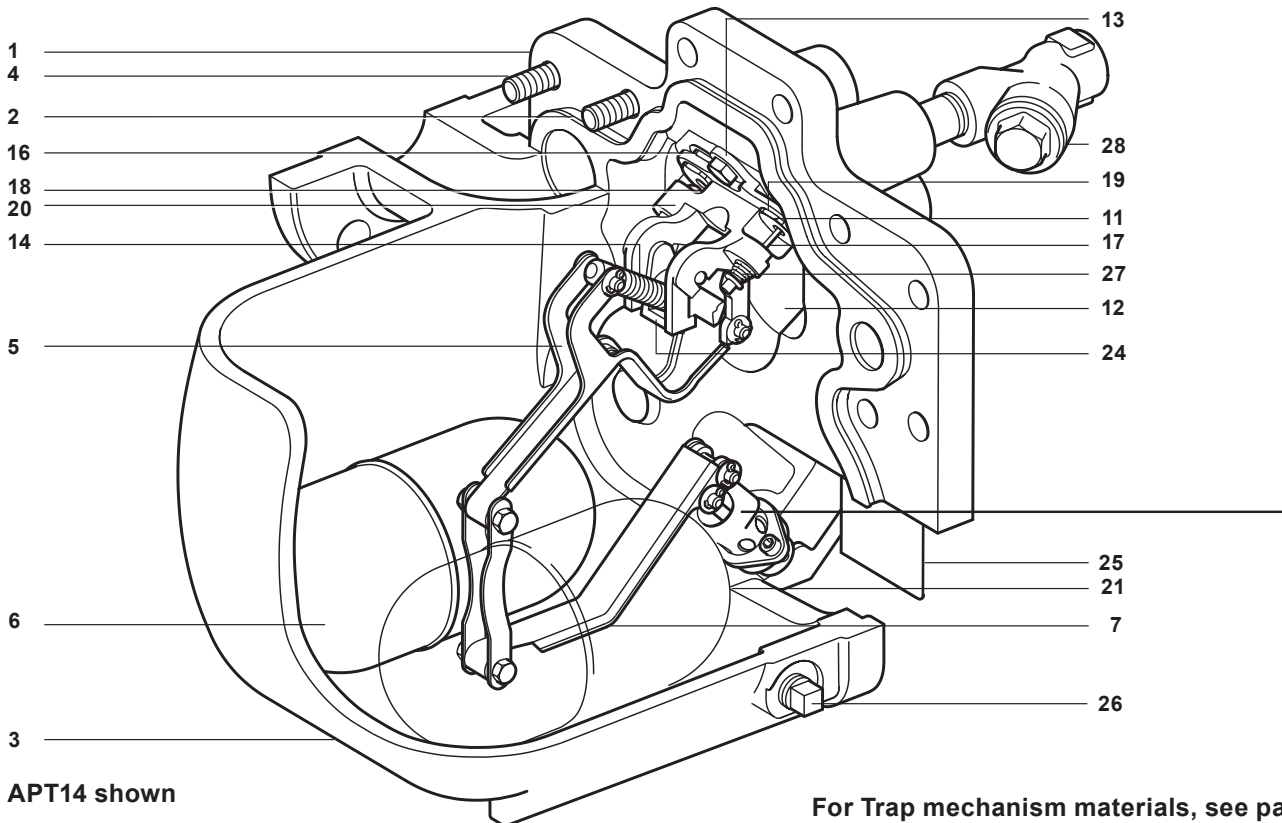

Materials for the trap mechanism

No. Part	Material	
8 Trap 2nd stage valve	Stainless steel	ASTM A276 440 B
9 Trap housing	Stainless steel	BS 3146 ANC 2
10 Ball (APT14 only)	Stainless steel	ASTM A276 440 B
15 Split pin	Stainless steel	BS 1574
21 Trap housing bolt	Stainless steel	BS 6105 A4 80
22 Trap 1st stage valve	Stainless steel	BS 970 431 S29 or ASTM A276 431
23 'O' ring	EPDM	

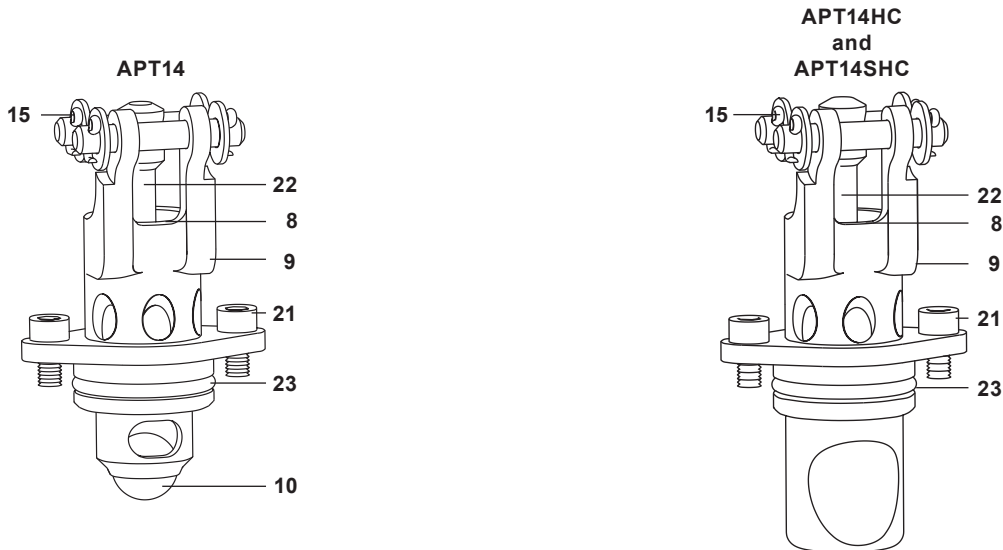

Safety information, installation and maintenance

For full details see the Installation and Maintenance Instructions (IM-IBR17-43IN) supplied with the product.

How to specify

APT14 and APT14HC

The pump trap shall be a Spirax Sarco automatic pump trap type APT14 operated by steam to 13.8 bar g. No electrical energy shall be required. Body construction from SG iron (EN JS 1025 dual certified with ASTM A395) with a swing type inlet check valve (APT14 and APT14HC) and ball type outlet check valve (APT14 only). The internal trap mechanism shall contain dual stainless steel floats connected with a two stage trap, while the internal pump mechanism shall be a stainless steel single tension spring snap-action device with no external seals or glands.

APT14SHC

The pump trap shall be a Spirax Sarco automatic pump trap type APT14SHC operated by steam to 13.8 bar g. No electrical energy shall be required. Body construction from carbon steel (EN 1.0619 dual certified with ASTM A216 WCB) with a swing type inlet check valve. The internal trap mechanism shall contain dual stainless steel floats connected with a two stage trap, while the internal pump mechanism shall be a stainless steel single tension spring snap-action device with no external seals or glands.

How to order

Example: 1 off Spirax Sarco automatic pump trap, type APT14, DN40 x DN25, flanged EN 1092 PN16 with BSP motive fluid connections.

Optional extras

Both the APT14 and APT14HC are available with the **body and cover coated with electroless nickel plate (ENP)**. This option, when required, will be denoted as **APT14 ENP** and **APT14HC ENP** respectively and must be stated at the time of order placement.

The APT14, APT14HC and APT14SHC are available with the body drilled, tapped and plugged to accept sight level gauges. **Note:** Sight level gauges can not be fitted retrospectively to the standard APT14, APT14HC or APT14SHC.

Sight level gauges, supplied separately, are available for the APT14, APT14HC or APT14SHC. For further details contact Spirax Sarco.

Spare parts

The spare parts available are shown in solid outline. Parts drawn in a grey line are not supplied as spares.

Available spares

A	Cover assembly (A - G inclusive)	1, 2, 5-25
B	Cover gasket	2
C	Inlet check valve	2, 12
D	Spring and actuator arm	2, 14, 24
E	Floats	2, 5, 6, 7
F	Trap and outlet check valve mechanism	2, 8, 9, 10 (APT14 only), 21, 22, 23
G	Inlet/exhaust valve and seat kit	2, 16, 17, 18, 19, 27
H	See separate literature: For the APT14 , APT14HC and APT14SHC see TI-IBR16-08IN	28
DCV10 outlet check valve (APT14HC and APT14SHC only). See separate literature TI-IBR17-58IN		29

Please note:

For customer convenience, spares are supplied in kits to ensure all the appropriate replacement parts are available e.g. when an inlet/exhaust valve and seat assembly is ordered, all replacement split pins, washers and gaskets will be provided in addition to the key components listed.

How to order spares

Always order spares by using the description given in the column headed 'Available spares' and state the size and type of unit.

Example: 1 off Inlet/exhaust valve and seat kit for a Spirax Sarco DN40 x DN25 APT14 automatic pump trap.

A Cover assembly (APT14 shown)

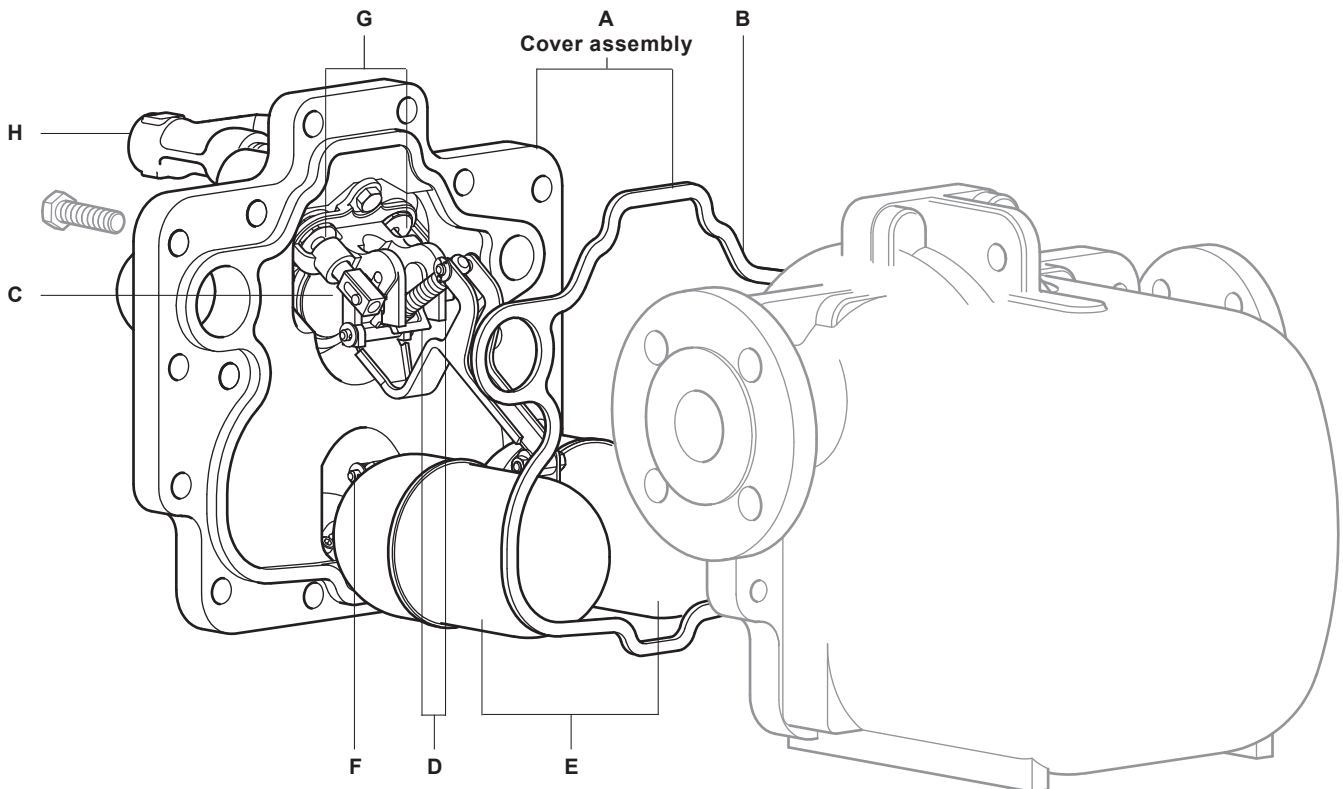

B
Cover gasket

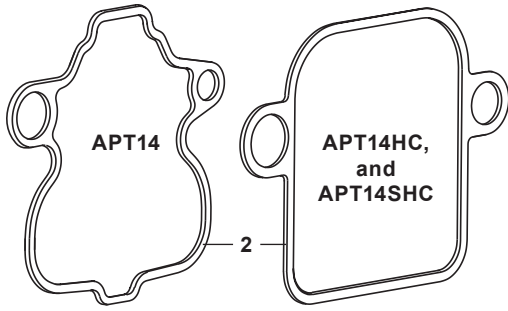

C
Inlet check valve

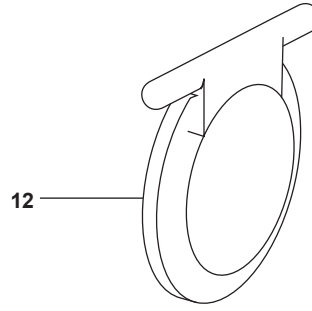

D
Spring and actuator arm

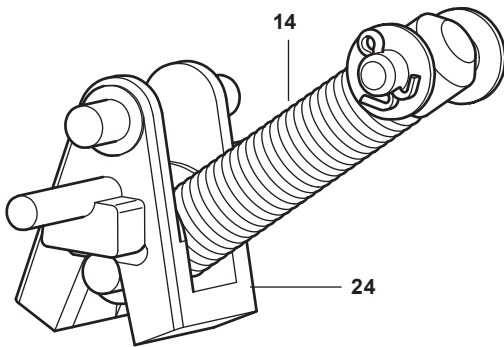

E
Floats

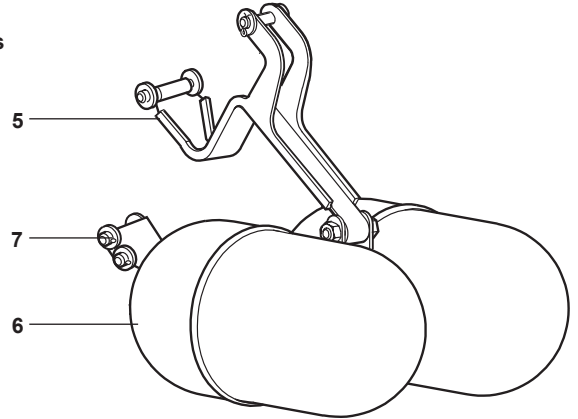

F
Trap and outlet check valve mechanism
Note: Item 10 is not included for the APT14HC and APT14SHC

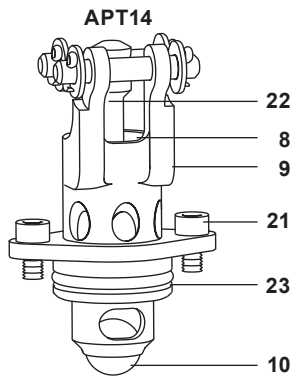

APT14HC and APT14SHC

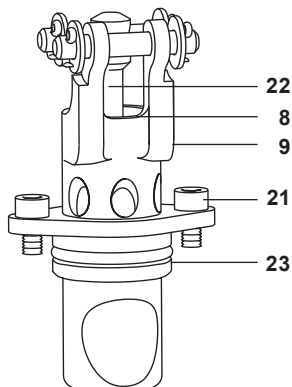

G
Inlet / exhaust valve and seat kit

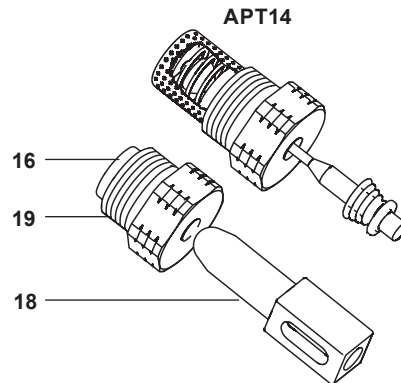

APT14HC and APT14SHC

